

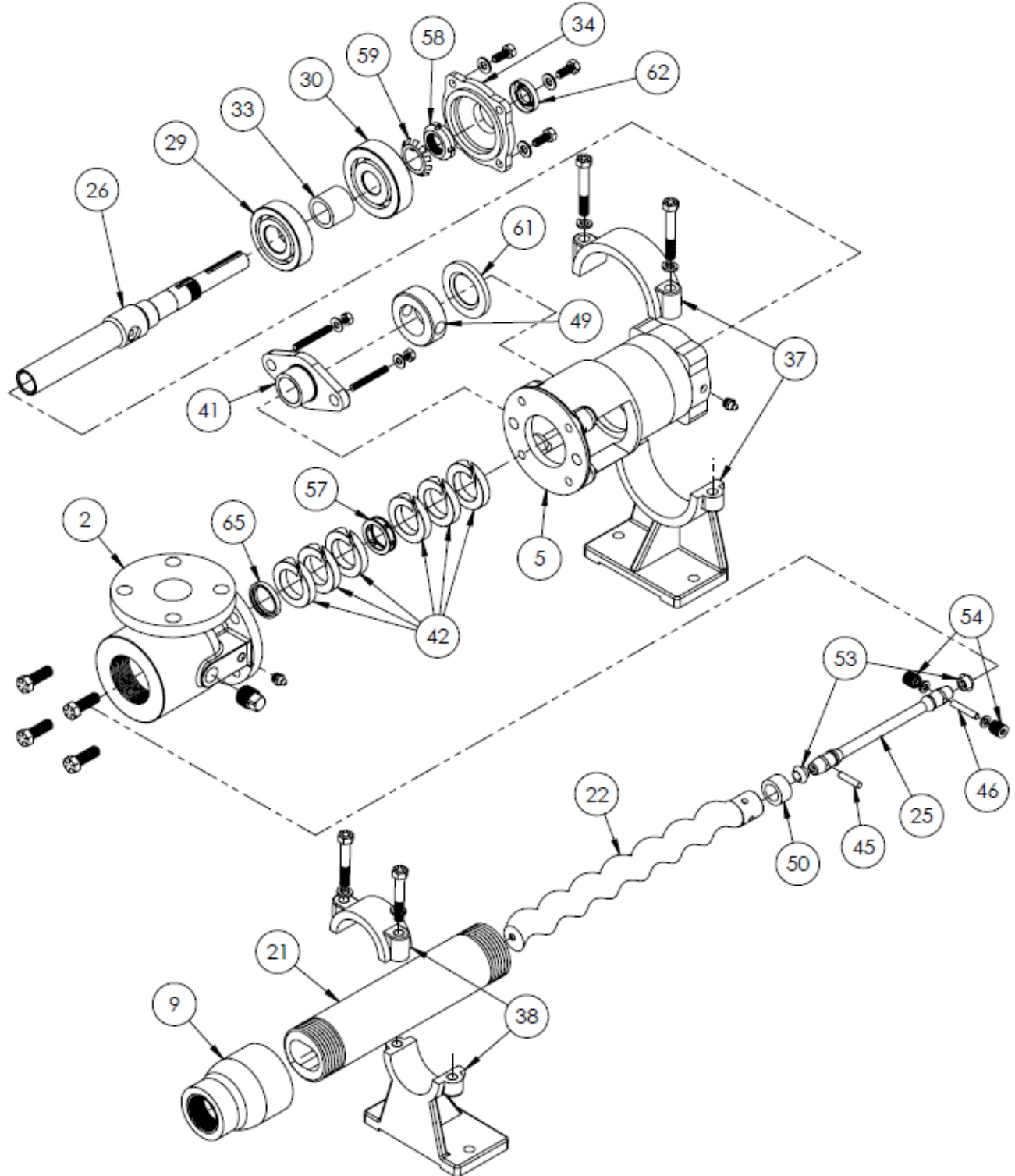

Continental Progressive Cavity Pump CL Model CL6 Pump



Continental Pump Company

29425 State Hwy B | Warrenton, Missouri 63383 | Tel: 636-456-6006 | Fax: 636-456-4337 | Email: sales@con-pump.com
Visit us at: www.continentalultrapumps.com



CL Model Number Nomenclature:

Materials used in the pumps are based on the fluid to be handled and are indicated in the model number nomenclature.

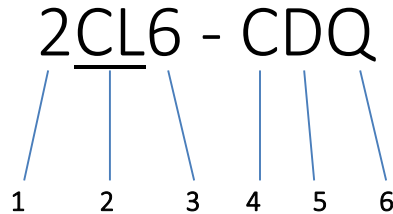

- (1): Indicates the number of stages for the rotor and stator
- (2): Indicates the pump model designation (CL, CM, CG Model)
- (3): Indicates the size of the rotor and stator
- (4): Indicates the pump body casting material
- (5): Indicates the rotor and internal parts material
- (6): Indicates the stator material

Continental Part Description	Continental Letter Designation	Part Materials
Pump Body	C	Cast Iron
	S	316 Stainless Steel (CF8M)
Rotor	D	Chrome Plated Alloy Steel
	S	Chrome Plated Stainless Steel
Stator*	Q	Buna Nitrile
	R	Natural Rubber
	B	EPDM
	F	Viton®
Internal Parts	CS	Carbon Steel
	S	Stainless Steel

*The Stator Elastomers can be furnished in either: C – Carbon Steel Sleeve or S – Stainless Steel Sleeve.

Example: QC is for Buna Nitrile Elastomer with Carbon Steel Sleeve.

Packing Sets: All sets are Formed and Cut Rings.

Teflon coated: General Service to handle are Caustics, mild acids, chemicals, solvents, oils. Temperature to 300°, pH range 2-10.

Graphite: General Service to handle are Strong caustics, acids, chemicals and high pressure steam. Temperature to 1200° in steam and 800° in oxidizing atmospheres, pH range 0-14.

Continental Pump Company

29425 State Hwy B | Warrenton, Missouri 63383 | Tel: 636-456-6006 | Fax: 636-456-4337 | Email: sales@con-pump.com
Visit us at: www.continentalultrapumps.com



CL Model

Replacement Parts for CL6 Pump

Part	Part Name	Continental Pump Part Number	For Continental Pump Model
	Suction Body	CL6-2C CL6-2S	CL6
	Bearing Housing	CL6-5C	CL6
	Reducer	CL6-9C CL6-9S	CL6
	Stator*	1CL6-21QC 1CL6-21BC 1CL6-21RC 1CL6-21FC	CL6
		2CL6-21QC 2CL6-21BC 2CL6-21RC 2CL6-21FC	CL6
		3CL6-21QC 3CL6-21BC 3CL6-21RC 3CL6-21FC	CL6

*Other elastomer options are available upon request

Continental Pump Company

29425 State Hwy B | Warrenton, Missouri 63383 | Tel: 636-456-6006 | Fax: 636-456-4337 | Email: sales@con-pump.com
Visit us at: www.continentalultrapumps.com



Part	Part Name	Continental Pump Part Number	For Continental Pump Model
	Stator*	1CL6-21QS 1CL6-21BS 1CL6-21RS 1CL6-21FS	CL6
		2CL6-21QS 2CL6-21BS 2CL6-21RS 2CL6-21FS	CL6
		3CL6-21QS 3CL6-21BS 3CL6-21RS 3CL6-21FS	CL6
*Other elastomer options are available upon request			
	Rotor**	1CL6-22D 2CL6-22D 3CL6-22D	CL6
		1CL6-22S 2CL6-22S 3CL6-22S	CL6
**Undersized and Non-Plated Rotors are available upon request			
	Connecting Rod	CL6-25CS CL6-25S	CL6
	Drive Shaft	CL6-26CS CL6-26S	CL6
	Ball Bearing (Radial)	CL6-29	CL6
	Ball Bearing (Thrust)	CL6-30	CL6
	Bearing Spacer	CL6-33CS	CL6

Continental Pump Company

29425 State Hwy B | Warrenton, Missouri 63383 | Tel: 636-456-6006 | Fax: 636-456-4337 | Email: sales@con-pump.com
 Visit us at: www.continentalultrapumps.com









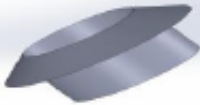

Part	Part Name	Continental Pump Part Number	For Continental Pump Model
	Bearing Cover Plate	CL6-34C	CL6
	Pump Support	CL6-37C	CL6
	Stator Support***	CL6-38C	CL6
	Packing Gland	CL6-41C CL6-41S	CL6
	Packing Set, Teflon Coated	CL6-42	CL6
	Packing Set, Graphite	CL6-42G	CL6
	Rotor Pin	CL6-45CS CL6-45S	CL6
	Shaft Pin	CL6-46CS CL6-46S	CL6
	Shaft Collar	CL6-49CS	CL6

***2 Stator Supports are required for 3CL6 pumps.

Continental Pump Company

29425 State Hwy B | Warrenton, Missouri 63383 | Tel: 636-456-6006 | Fax: 636-456-4337 | Email: sales@con-pump.com
Visit us at: www.continentalultrapumps.com



Part	Part Name	Continental Pump Part Number	For Continental Pump Model
	Rotor Band	CL6-50CS CL6-50S	CL6
	Connecting Rod Washer (2 Req.)	CL6-53Q CL6-53B CL6-53F	CL6
	Drive Pin Retainer Screw (2 Req.)	CL6-54CS CL6-54S	CL6
	Lantern Ring, 1 Piece	CL6-57S	CL6
	Bearing Lock Nut, Carbon Steel	CL6-58	CL6
	Bearing Lock Washer, Carbon Steel	CL6-59	CL6
	Grease Seal (Radial)	CL6-61	CL6
	Grease Seal (Thrust)	CL6-62	CL6
	Packing Gland Insert	CL6-65S	CL6
	Drive Pin Washer, Stainless Steel (2 Req.)	CL6-73	CL6

Continental Pump Company

29425 State Hwy B | Warrenton, Missouri 63383 | Tel: 636-456-6006 | Fax: 636-456-4337 | Email: sales@con-pump.com
 Visit us at: www.continentalultrapumps.com



Part	Part Name	Continental Pump Part Number	For Continental Pump Model
	Component Seal	CL6-81F	CL6
*Other elastomer options are available upon request			
	Component Seal Gland	CL6-82S	CL6
<i>No Image Available</i>	Cartridge Mechanical Seal	Contact Us	CL6

Continental Pump Company

29425 State Hwy B | Warrenton, Missouri 63383 | Tel: 636-456-6006 | Fax: 636-456-4337 | Email: sales@con-pump.com
 Visit us at: www.continentalultrapumps.com



CL Model



Replacement Kits for CL6 Pump

Part	Part Name	Continental Pump Part Number	For Continental Pump Model
	<u>Hydraulic Motor Kit</u> Includes: Hydraulic Motor, Motor Adapter, Adapter Flange (CL6-35A), Grease Seal (CL6-62), & Couplings: L-100 x 1", L-100 x 1 1/8" & L-099/100 Sox Spider.	CL6-HYD	CL6
	<u>Hydraulic Kit (No Motor)</u> Includes: Hydraulic Motor Adapter, Adapter Flange (CL6-35A), Grease Seal (CL6-62) & Couplings: L-100 x 1", L-100 x 1 1/8" & L-099/100 Sox Spider.	CL6-HYDNM	CL6
	<u>Connecting Rod Kit:</u> includes: QTY 1: Connecting Rod, Rotor Pin, Shaft Pin, Rotor Band. QTY 2: Connecting Rod Washers, Drive Pin Retainer Screws and Drive Pin Washers.	CL6-25KQC CL6-25KBC CL6-25KFC	CL6
		CL6-25KQS CL6-25KBS CL6-25KFS	CL6

Continental Pump Company

29425 State Hwy B | Warrenton, Missouri 63383 | Tel: 636-456-6006 | Fax: 636-456-4337 | Email: sales@con-pump.com
 Visit us at: www.continentalultrapumps.com



Part	Part Name	Continental Pump Part Number	For Continental Pump Model
	<p><u>Bearing Kit:</u> Includes: Ball Bearing (Radial & Thrust), Bearing Spacer, Bearing Lock Nut & Washer, Grease Seal (Radial & Thrust).</p>	CL6-29K	CL6
	<p><u>Component Seal Kit:</u> Includes QTY 1: Viton Component Seal & Stainless Steel Gland</p>	CL6-81KFS	CL6

Continental Pump Company

29425 State Hwy B | Warrenton, Missouri 63383 | Tel: 636-456-6006 | Fax: 636-456-4337 | Email: sales@con-pump.com
 Visit us at: www.continentalultrapumps.com



Materials of Construction

All Continental Pump casting materials are Class 40# grey cast iron and CF8M (316) stainless steel. The best metal for your application would depend on how corrosive your liquid is. We offer an epoxy coating for an additional charge and can be applied to the suction housing and reducer. The epoxy seals the cast iron from the material being pumped.

Stators are available in 4 types of elastomers. The rubber materials are: Buna Nitrile, Natural Rubber, EPDM and Viton®. The rubber that is best for your application depends on what liquid you are pumping and at what temperature, as it plays a vital role in which to select.

The rotors are available in Chrome Plated Alloy Steel and Stainless Steel, but is dependent on the pH level and the corrosiveness of your liquid. In certain pH levels a non plated rotor may need to be used, as it could lift the chrome off of the rotor.

Looking for simplicity? We offer complete Progressive Cavity Pump Units. They are constructed on a steel base to fit your specific application needs. The Unit consists of a Pump, a Steel Base & Guard, a Gear Reducer and Motor. Also available are Belt Drive Units and many other base options.

Space Challenged? If you are needing a different arrangement from traditional piping, we can rotate the housing up to 270° for the CL, CM & CG Model Pumps.

Don't need a complete pumping unit but looking for drive options? We can still help, whether attached to a pump or sold separately we can supply you with Hydraulic Adapters, VFD's, Gear Boxes and Motors.

Continental Pump Company

29425 State Hwy B | Warrenton, Missouri 63383 | Tel: 636-456-6006 | Fax: 636-456-4337 | Email: sales@con-pump.com
Visit us at: www.continentalultrapumps.com